

TOPAZ FROM DEVIL'S HEAD, COLORADO

M. A. PEACOCK, *Harvard University.*

With field notes by Arthur Montgomery and Edwin Over, Jr.

ABSTRACT

Renewed operations in the pegmatites of Devil's Head, in the Pike's Peak region, have yielded a suite of noteworthy crystals of topaz associated with quartz, microcline, albite, fluorite and cassiterite. The collection includes some topaz crystals of outstanding size and regular development and many smaller crystals of unusually distorted habits. The forms observed are: $c(001)$, $b(010)$, $g(130)$, $l(120)$, $m(110)$, $X(023)$, $f(011)$, $y(021)$, $h(103)$, $d(101)$, $i(113)$, $u(112)$, $o(111)$, $r(121)$, on the preferred parameters of Kokscharov. One crystal shows alteration to a mineral of the kaolin group, and they all exhibit corrosion effects, some of which are suitable for geometrical description.

In the summer of 1934 Montgomery and Over resumed field operations in the Pike's Peak region of Colorado and succeeded in uncovering a suite of topaz crystals which are superior to any obtained hitherto from this locality. A selection of the best crystals, together with specimens of the associated minerals, was acquired by the Harvard Mineralogical Museum and entrusted to the first-named author for description. The material was obtained from Devil's Head in the extreme east of the Pike's Peak region.¹ The locality was described in an early paper by Whitman Cross and W. F. Hillebrand,² the occurrence of topaz at Devil's Head being particularly noted in an appendix by W. B. Smith.³ The new material and its associations conform in their main features with the above descriptions; the present paper is therefore concerned mainly with the novel features displayed by the newly found crystals.

The topaz was found in whole crystals and crystal fragments associated with quartz, microcline, albite, muscovite, rare fluorite and very rare cassiterite in pockets in pegmatite. The pockets, the largest of which is about $1 \times 2 \times 4$ feet in size (figure 1), are numerous in a zone of the pegmatite some 3 or 5 feet deep and of undetermined extent. The coarsely crystallized pegmatite merges

¹ Devil's Head (9348 feet) lies in $39^{\circ}16'$ N., $105^{\circ}06'$ W., on the topographic sheet "Platte Canyon," 1:125,000, *U.S.G.S.*, 1893.

² Minerals from the neighborhood of Pike's Peak, *U.S.G.S.*, Bull. 20, pp. 40-73, 1885.

³ Appendix: Notes upon the occurrence of Topaz at Devil's Head mountain, *U.S.G.S.*, Bull. 20, pp. 73-74, 1885.

into a narrow zone of graphic granite in the vicinity of the pockets and then spreads into the coarse quartz and microcline of the pocket walls, where frozen masses of feldspar are in some cases nearly a foot in diameter. Within the pockets the microcline masses reach 6 or 8 inches in greatest dimension; well-formed crystals are relatively rare and they do not exceed a size of two inches. Quartz occurs in smoky crystals, in most cases slender and distorted and in some cases coated with minute crystals of hematite. In the material available for study cassiterite is represented in two imperfect crystals, $3/4$ and $1/2$ inch in size, with large faces of $s(111)$

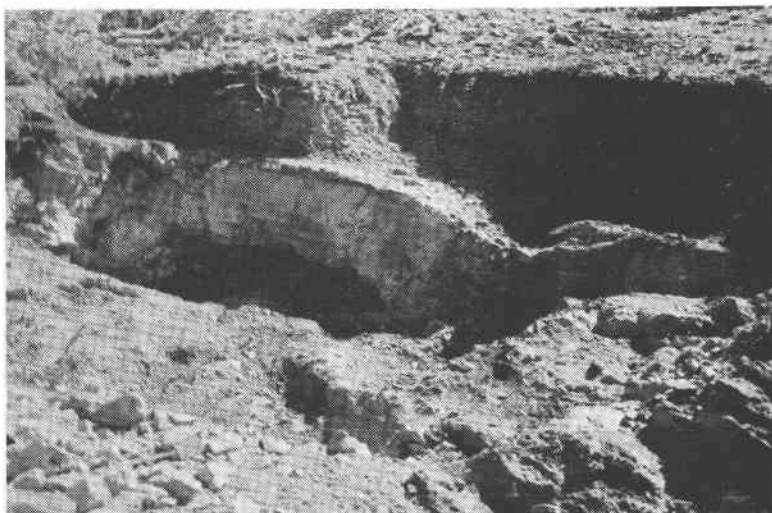

FIG. 1. One of the largest pockets, 1 foot high, 2 feet deep and 4 feet wide, in the pegmatite of Devil's Head, Colorado.

and narrow faces of $e(101)$. Fluorite is present as a bleached and crumbly pea-sized octahedron with small rough faces of the cube.

The crystals and fragments of topaz range from fist-size downward. The best-formed crystals were found loose or weakly cemented in a ferruginous mud or sand that covers the bottoms of many of the pockets. The mud contains solid ferruginous masses up to 2 lbs. in weight, and it is noteworthy that the pockets especially rich in iron are poor in topaz. The sandy pocket material appears to be derived from the albite. Distorted topaz crystals occur tightly wedged between crystals of quartz and masses of albite. Shapeless

masses of reddish, opaque and somewhat altered topaz occur in the solid pegmatite adjoining the pockets both above and below. The detached and shattered condition of many of the topaz crystals and the bent and broken state of the mica in the solid pegmatite point to mechanical disturbance of the pegmatite subsequent to the formation of the pocket minerals. The corroded and altered condition of many of the topaz crystals, extending to cleaved and fractured surfaces, and the abundant infiltration of iron oxide into the pockets, indicates the action of travelling solutions after the period of crystal disturbance.

The selected material comprises six well-developed topaz crystals of considerable size, a dozen variously distorted smaller crystals, a portion of a large crystal, and a large rough crystal partly replaced by some other substance. Most of the unaltered crystals are stained pale red, mainly on the surface and along cleavage cracks; internally they are nearly colorless and transparent and only slightly flawed by basal cleavage cracks and other fractures. A few smaller crystals, later added to the collection, are perfectly colorless, giving flawless cut stones. The crystals permit good contact measurements by means of which the following forms were determined:

c (001)
b (010) *g*(130) *l*(120) *m*(110)
X(023) *f*(011) *y*(021)
h (103) *d*(101)
i (113) *u*(112) *o*(111) *r*(121)

All the forms are well known on topaz; they were determined by several readings on each form in good agreement with the calculated angles⁴ given below:

<i>bg</i> = 32°14½'	<i>cX</i> = 32°27'	<i>ch</i> = 31°02'	<i>ci</i> = 34°14'	<i>cr</i> = 69°09½'
<i>bl</i> = 43 25	<i>cf</i> = 43 39	<i>cd</i> = 61 00½	<i>cu</i> = 45 35½	<i>yr</i> = 39 57½
<i>bm</i> = 62 03½	<i>cy</i> = 62 20		<i>co</i> = 63 54	<i>dr</i> = 42 45½

The symbols and angles given correspond to the orthorhombic elements of Kokscharov,⁵ $a:b:c=0.5285:1:0.9540$, in modern conventional form. Kokscharov's orientation, adopted by Goldschmidt⁶ in his numerous studies on topaz, leads to completely satisfactory correspondence between the relative importance of the forms and the relative simplicity of their indices (figure 2).

⁴ Extracted from Goldschmidt's *Winkeltabellen*, 1897.

⁵ *Materialien zur Mineralogie Russlands*, II, p. 198, 1854-57.

⁶ *Beitr. Kryst. Min.*, III, p. 172, footnote 3, 1934.

Dana⁷ adopted another setting which is related to that of Kokscharov as follows:

$$a:b:c \text{ (Dana)} = a:b:\frac{1}{2}c \text{ (Kokscharov)}$$

$$h \ k \ l \text{ (Dana)} = 2h \ 2k \ l \text{ (Kokscharov)}$$

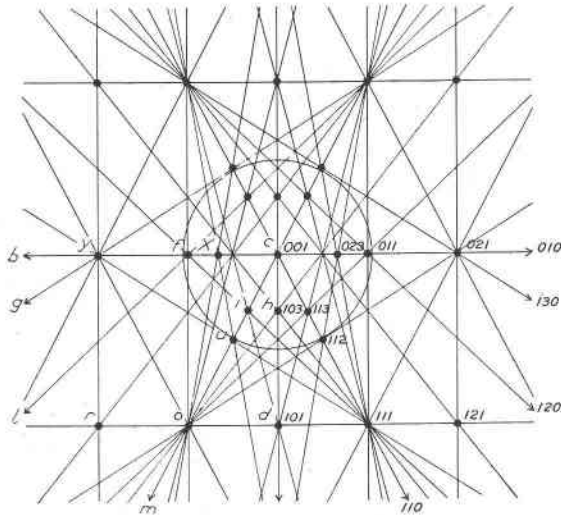

FIG. 2. Topaz. Gnomonic projection of the forms found on the crystals from Devil's Head. Observe the subhexagonal pattern and the importance of the poles of *o*(111), the preferred unit form, as zonal nodes.

Forms: *c*(001), *b*(010), *g*(130), *l*(120), *m*(110), *X*(023), *f*(011), *y*(021), *h*(103), *d*(101), *i*(113), *u*(112), *o*(111), *r*(121).

In this setting the symbols of the principal forms are relatively less simple and some rare forms receive the simplest indices. It is interesting to note that the ratio of the cell sides of topaz, determined röntgenographically by Alston and West,⁸ agrees with Kokscharov's elements to the fourth place of decimals.

The selected crystals, grouped under five types according to the development of the prism zone, show the following combinations of forms:

⁷ *System*. 6th ed. 1892.

⁸ *Zeit Kryst.*, vol. 69, p. 150, 1928.

TYPE	CRYSTAL	COMBINATION
I	1	<i>c</i> . <i>g l m X f y</i> . <i>d i u o</i> .
	2	<i>c b g l m X f y h d i u o</i> .
	3	<i>c b . l m X f y h d . u o</i> .
	4	. . . <i>l m X f . h d . u o</i> .
	5	<i>c . . l m X f y . . . u o</i> .
	6	<i>c b g l m X f y h d i u o r</i>
	7	. . . <i>l m . f y . . i . o</i> .
	8	. <i>b . l m . f y . d . . o</i> .
	9	. . . <i>l m . f y o</i> .
II	10 <i>m . . y . d i . o</i> .
	11	. . <i>g l m X f y . . . o</i> .
	12	. . . <i>l m . . y . d . . o</i> .
III	13	. <i>b g l m . f y . . i . o</i> .
	14	. <i>b . l . . . y . d . u o</i> .
IV	15	. <i>b g l m . f y . d . . o</i> .
V	16	<i>c b . l m X . y . d i . .</i> .
	17	. . . <i>l m . f y . . . o</i> .
	18	. . . <i>l m . f y . d . . o</i> .
	19	. . . <i>l m . f y . d i u o</i> .

TYPE I. The crystals of this type have a stout columnar habit due to like development of the pseudo-hexagonal prism *m* and the pseudo-tetragonal prism *l*. Crystal 1 (figure 3) is the largest in the collection and probably the largest well-formed and well-preserved topaz crystal found in North America.⁹ It measures $8.2 \times 11.0 \times 8.0$ cm. in the directions of the axes, *a*, *b*, *c*, respectively, and weighs 1160 gm. All the forms are represented by good faces except the base *c* and the brachydome *X*. The latter is formed in reality by the summits of small, close-set corrosion residuals which evidently represent *X* rather than the steeper brachydome *f*. This appears from the fact that the faces of the low pyramid *i* are certainly not corrosion faces, which they would be had *X* developed by corrosion of *f*. The base *c*, although rough, is then also a true form.

⁹ Cavernous ruins of much larger topaz crystals, resulting from far advanced solution, have been described from Topsham, Maine, by Palache, *Am. Jour. Sci.*, vol. 27, p. 37, 1934.

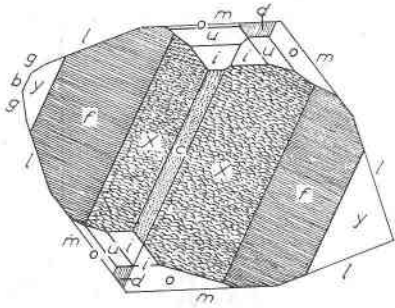

FIG. 3. Type I, Crystal 1, showing the characteristic etch effects on *c*, *X*, *f*, *d*.

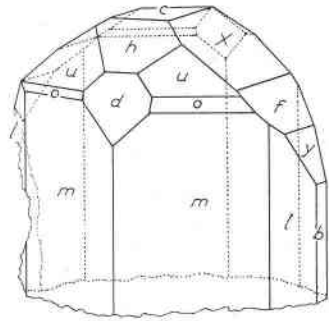

FIG. 4. Type I, Crystal 3.

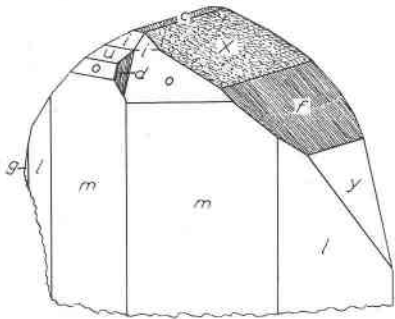

FIG. 5. Type I, Crystal 5.

Crystal 2 measures $5.6 \times 7.5 \times 5.8$ cm.; it is similar to crystal 1 and likewise an outstanding specimen. Crystal 3 (figure 4), $3.3 \times 4.3 \times 3.9$ cm., is remarkable for the relatively large development of a face of the macrodome *h*. Crystal 4 measures $3.6 \times 4.8 \times 4.1$ cm. and resembles crystal 3. Crystal 5 (figure 5), $3.3 \times 4.1 \times 6.0$ cm., is a tall, well-formed specimen of relatively simple development. Crystal 6 (figure 6) is an unequally developed example measuring $2.8 \times 4.5 \times 4.8$ cm.; it is the only specimen showing all the forms and the only one with the pyramid *r*. These six crystals are the finest in the collection.

The remaining crystals range from 4.3 cm. in the greatest dimension to 0.4 in the least. For the most part they lack the regularity

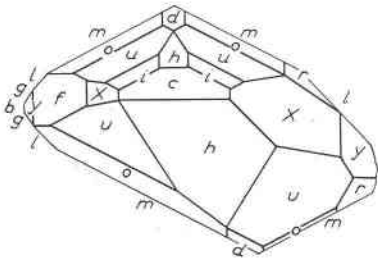

FIG. 6. Type I, Crystal 6, showing all the forms observed at this locality.

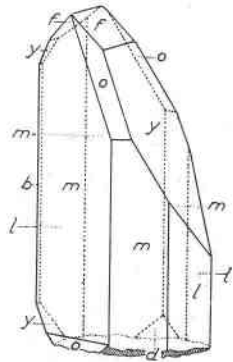

FIG. 7. Type I, Crystal 8.

and quality of the larger crystals and show unusual inequalities of development. Three of these may be classed with Type I: crystal 7 is a simple incomplete example; crystal 8 (figure 7) is cut aslant by a large face of the brachydome y ; crystal 9 is terminated at both ends mainly by badly corroded faces of the same form.

TYPE II. In this type the prism zone is dominated by m . In crystal 10 (figure 8) the development is fairly regular; crystal 11 shows marked flattening with m ; crystal 12 has o and d on both terminations.

TYPE III. The appearance of these crystals is controlled by the development of the prism l . Crystal 13 (figure 9) is strongly flattened with l and doubly terminated; crystal 14 is similar.

TYPE IV. A single specimen, crystal 15 (figure 10) is strongly flattened with the prism g , which on other crystals is only an insignificant form.

TYPE V. The four remaining crystals are mainly combinations of domes and pyramids with subordinate prismatic forms. In crystal 16 (figure 11) a relatively large base is combined with the nearly hexagonally arranged faces of the brachydome X and the pyramid i . Crystal 17 is a parallel growth of two short irregular individuals with remnants of double terminations. Crystal 18 has d and o above and below. Crystal 19 combines a large base below with domes and pyramids above, giving the hemimorphic appearance occasionally observed on topaz.¹⁰

¹⁰ Adams and Graham, *Trans. Roy. Soc. Canada*, vol. **XX**, sec. 4, p. 134, 1926. Alston and West, *Zeit. Kryst.*, **69**, p. 149, 1928, assigned the structure of Nigerian topaz to the holohedral class of the orthorhombic system.

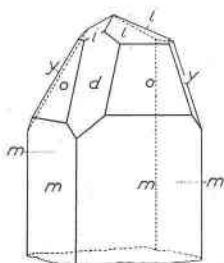

FIG. 8. Type II, Crystal 10.

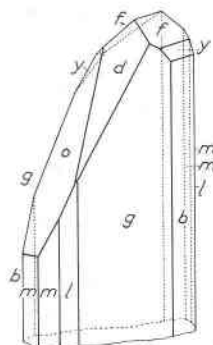

FIG. 10. Type IV, Crystal 15.

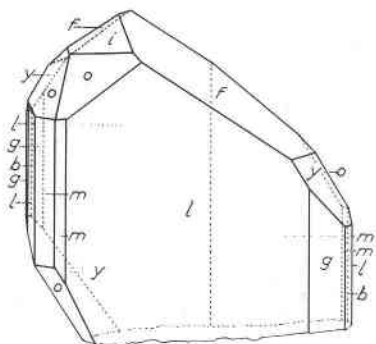

FIG. 9. Type III, Crystal 13.

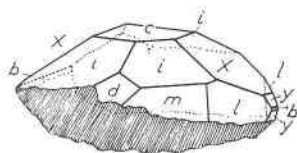

FIG. 11. Type V, Crystal 16.

The etching on these topaz crystals shows some interesting features. As is usually the case, different forms have offered unlike resistance to corrosion: generally the base and the terminal forms with smaller polar distances have suffered most while the forms with greater polar distances have best withstood the attack of the corroding fluids. This is also true of the doubly terminated crystals, showing that the selective corrosion is due not to unequal exposure to attack but to unequal resistance of planes in different directions through the crystal structure.

The brachydome zone $[c b]$ shows strong and characteristic corrosion which is present on all the crystals and aids considerably in orientating the distorted examples. The base c is strongly pitted, in some cases with regular lozenge-shaped etch pits whose longer and shorter diagonals are parallel to the corresponding crystal axes. The pits are 0.5 to 1.0 mm. long and each is lined by a somewhat rounded negative pyramid from which a reflection was not obtained. The azimuth of this corrosion form is given, however,

by the angle of lozenge which was measured on a photograph on c taken with the axis of the camera parallel to the c -axis. The azimuth angle was thus found to be 68° , from which it follows that the corrosion pyramid has a complex symbol of the form $43l$.

The most striking etch effects on the crystals are the beautifully formed corrosion knobs on the brachydome X . The surface of X is composed wholly of these sub-hexagonal shield-shaped bodies lying, with much mutual interference, with their long axes in the plane of 100 . Crystal 3 was mounted on the two-circle goniometer, adjusted by means of reflections from thin glass plates stuck on adjacent prism faces, and the form of a typical corrosion knob on

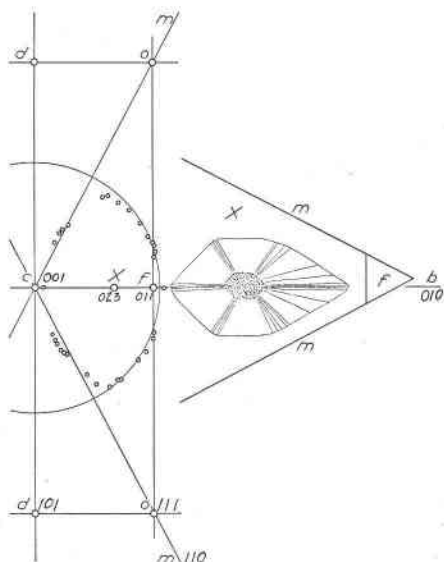

FIG. 12. Plan and gnomonic projection of a corrosion knob on $X(023)$.

X was determined by measuring and plotting the interrupted trains of reflections from its brilliant but curved surfaces. Figure 12 gives a plan of the corrosion knob, which is about a millimeter long, and the gnomonic projection of the reflection trains. The projection conforms to the orthorhombic symmetry of topaz, and some points on the trains approach simple rational positions. But it is evident that the corrosion form is mainly bounded by facets with highly complex symbols.

On the brachydome f the same etching that produced the etch knobs on X gives parallel furrows lying in the plane of (100) . At

the junction of f and y these furrows cease abruptly and give place to slight pitting on the steeper and relatively resistant plane y .

In the macrodome zone h is frequently marred by small sparse etch knobs. The edge between h and d is rounded with the formation of minute residual projections, and d is marked by fine, acutely downward tapering ridges lying in the plane of (010). The forms in the pyramid zone are variously marked with delicate patterns in which it is difficult to detect any significant regularity. The forms in the prism zone are mostly free from etch effects. The narrow brachypinacoid b is sometimes faintly marked by light striae lying in the plane of (001); the unit prism m is marked in some cases by feeble growth vicinals and occasionally etched with a rectangular panelled pattern.

These few observations on corrosion effects on topaz are in accord with the usual conclusion that corrosion forms conform to the symmetry of the crystal, although the component faces of such forms have complex symbols even when they give good reflections. It is probable that many of the complex symbols in the crystallographic literature are based on reflections from etched surfaces. If this were more constantly kept in mind, further additions of insignificant symbols to crystallographic form lists would be restrained.

In a study on the forms and accessories¹¹ of topaz, Goldschmidt¹² described several crystals from Florissant, which is in the Pike's Peak region of Colorado. While there is a general similarity between our crystals and those described by Goldschmidt, the corrosion forms on $X(023)$ observed on the Devil's Head material have no counterpart in Goldschmidt's stereographic projections of the accessories on the Florissant crystals. This is no doubt due to differences in the solution conditions which are known to produce different solution forms on crystals of the same species.

It remains to mention the alteration product which has partly replaced one large rough topaz crystal in the collection. The material appears in nests of minute radially arranged white fibres or plates with pearly lustre. On this substance Mr. Berman observed a mean refractive index of 1.565, weak birefringence and positive elongation. These characters indicate a member of the kaolin group.

¹¹ An apt term proposed by Goldschmidt to distinguish all solution forms and vicinal growth forms from normal plane-faced growth forms. The latter are the only forms properly entitled to symbols and a place in a form list.

¹² *Zeit. Krist.*, vol. 40, p. 380, 1905.